

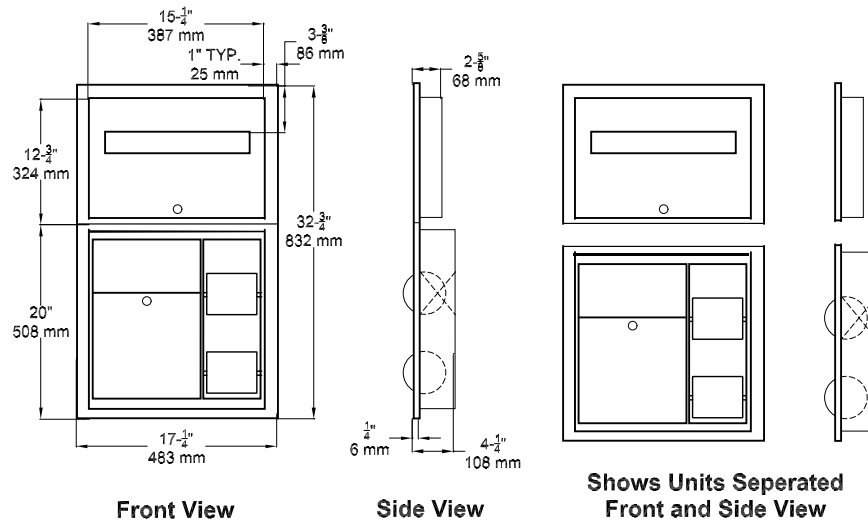

CU-311-280

Technical Data Sheet

**Toilet Seat Cover, Toilet Tissue Dispenser and Napkin Disposal  
Recessed – End Wall Unit**



**MATERIALS:** The unit is fabricated of 18-8, type 304 stainless steel with a No. 4 satin finish and is one piece seamless 22 gauge flange construction.

**SPECIFICATIONS:** The unit is fabricated of alloy 18-8, type 304 stainless steel with a No. 4 satin finish. The doors are mounted with continuous stainless steel piano hinge and are fitted with tumbler locks. The unit is a one piece seamless 22 gauge flange constructed with 1/4"(6 mm) return for rigidity. The 2 gallons waste receptacle is self-closing with a spring hinge, and is removable for servicing.

**CAPACITY:** Four standard 5 1/2"(140 mm) diameter 1800 sheet rolls, 500 seat covers and 2 gallons waste receptacle.

**OVERALL SIZE:** 17 1/4" W x 32 3/4" H x 4 1/4" D  
(438 mm W x 832 mm H x 108 mm D)

**WALL OPENING:** 15 3/4" W x 31 1/4" H x 4" D  
(400 mm W x 794 mm H x 102 mm D)

**MOUNTING HEIGHT:** ADA required mounting height is 46" (1,168 mm) above finished floor to top of unit.



**INSTALLATION:** Unit is to be installed through partitions 1/2" (13 mm) to 2" (51 mm) thick, serving two compartments. Toilet tissue rolls should be mounted with forward edge no more than 36" (914 mm) from the back wall of stall. All toilet tissue dispensers should be mounted with their horizontal centerline at least 19" (483 mm) from the finished floor. Mount centered through toilet partitions. ADA required mounting height is 46" (1,168 mm) above finished floor to top of unit.

The manufacturer reserves the right, without formal notification, to implement changes to the design and dimensions.  
© 2008 Columbia Accessories  
Edition CU-311-280/001



PO Box 181, Columbia, SC 29202  
Phone: 1-866-820-3579 Fax: 1-866-317-2786  
Web Site: <http://www.natpart.com>