

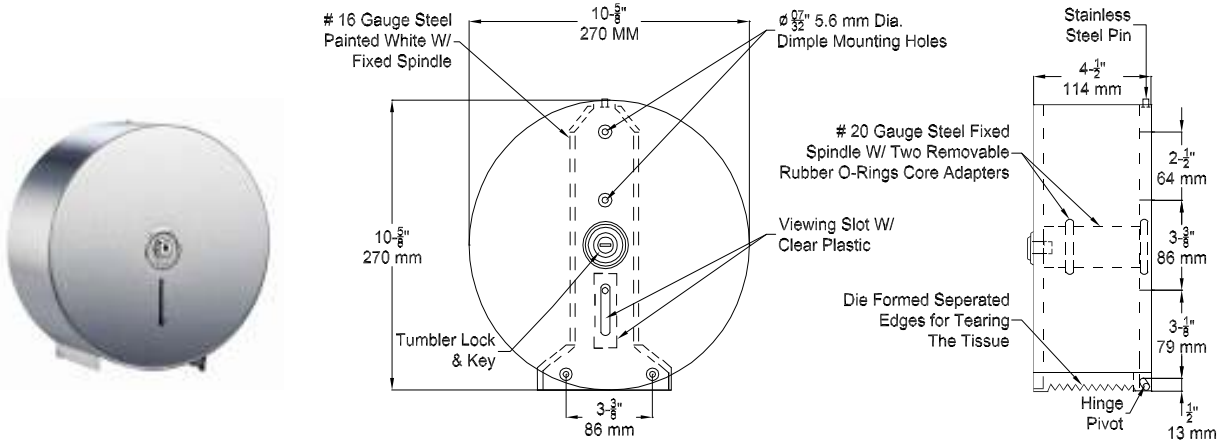

TT-171-200

Technical Data Sheet

Jumbo-Roll Toilet Paper Dispenser Surface Mounted



MATERIALS: Surface Mounted Jumbo Roll Toilet Paper Dispenser cover fabricated of alloy 18-8 stainless steel, type 304, 20 gauge with a No 4 satin finish. Cover will be of one piece construction hung on stainless steel pin hinges and will be held closed by a tumbler lock, key is provided.

CAPACITY: One 10" Toilet Tissue Roll

OVERALL SIZE: 10 5/8" W x 10 5/8" H x 4 1/2" D
(270 mm W x 270 mm H x 114 mm D)

SPECIFICATIONS: Surface Mounted Jumbo Roll Toilet Paper Dispenser holds one (1) roll up to 10" Diameter with 1-5/8" Diameter core or 2-1/4" Diameter core. Cover to be fabricated of alloy 18-8 stainless steel, type 304, 20 gauge with a No 4 satin finish. Rear of cabinet shall have five (5) mounting holes to suit #8 or #10 flat head screws. Cover will be of one piece construction hung on stainless steel pin hinges and will be held closed by a tumbler lock, key is provided. A viewing slot with clear plastic window will be provided. Unit accommodates a smaller core size roll by removing the rubber core adapter "O" rings. Opening on bottom of cabinet will have stainless steel teeth for toilet tissue tearing on both sides. Cover at top will have shoulder pin to interlock back plate when closed.

INSTALLATION: For general utility surface mount unit within 12" of front of toilet from center line and 31" above finished floor (AFF) from bottom of unit with five (5) screws (by others) through mounting holes provided. For compliance with ADA Accessibility Guidelines install unit so that leading edge of roll is no farther than 36" from back wall behind commode and centerline of roll is 19" minimum above finished floor (AFF) to 44" max. AFF

The manufacturer reserves the right, without formal notification, to implement changes to the design and dimensions.
© 2008 Columbia Accessories
Edition: TT-171-200/001



PO Box 181, Columbia, SC 29202
Phone: 1-866-820-3579 Fax: 1-866-317-2786
Web Site: <http://www.natpart.com>