

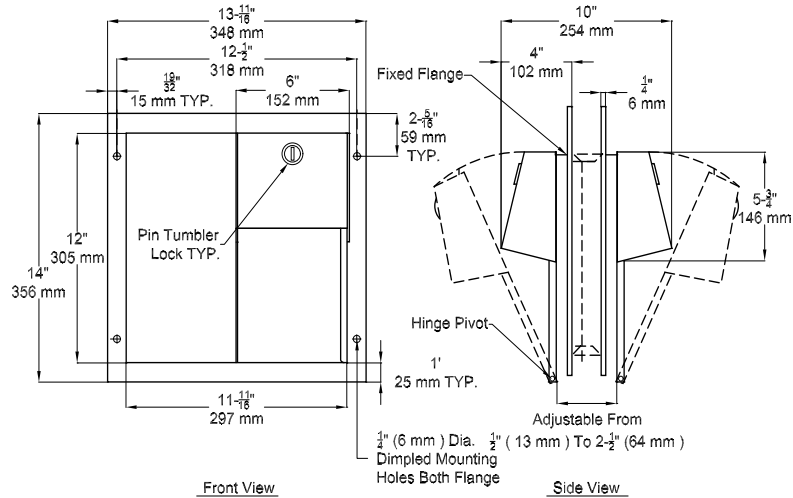

TT-341-200

Technical Data Sheet

**Dual Access Double Roll Toilet Paper Dispenser
Partition Mounted**



MATERIALS: Partition Mounted Dual Hide-A-Roll Toilet Tissue Dispenser doors, door frames and dispensing mechanism guide tracks fabricated of alloy 18-8 stainless steel, type 304, 18 gauge; cabinet body shall be same grade, 22 gauge. Structural assembly of body and door components will be of welded construction.

CAPACITY: Four Standard Toilet Tissue Rolls

OVERALL SIZE: 13 11/16" W x 14" H x 1/2" to 1 1/4" D
 (348 mm W x 356 mm H x 13 mm to 32 mm D)

PARTITION OPENING: 11 7/8" W x 12 1/8" H x 1/2" to 2-1/2" D
 (302 mm W x 308 mm H x 13 mm to 64 mm D)

SPECIFICATIONS: Partition Mounted Dual Hide-A-Roll Toilet Tissue Dispenser will hold and dispense four (4) standard or four (4) 5-1/4" diameter (133 mm) 1800 sheets tissue rolls and will have doors, door frames and dispensing mechanism guide tracks fabricated of alloy 18-8 stainless steel, type 304, 18 gauge; cabinet body shall be same grade, 22 gauge. All exposed surfaces to be No. 4 satin finish and be protected during shipment with a PVC film easily removable after installation. Internal mechanism levers to be fabricated of molded high-impact resistant plastic for smooth operation. Structural assembly of body and door components will be of welded construction. Door hinges will be of heavy-duty stainless steel 3/16" diameter rivets. Doors to be held closed with tumbler locks. Vandal resistant rollers shall be of molded high impact resistant plastic with integral molded-in stainless steel pins and four (4) rollers shall be supplied.

INSTALLATION: Unit is partition mounted using four (4) No 10 self tapping screws per side. Screws are supplied. Mounting holes are provided through fixed mounting frame and adjustable mounting frame. Mounting flanges adjust to accommodate partition thickness of 1/2" (13mm) minimum to 2-1/2" (64mm) maximum. For compliance with ADA Accessibility Guidelines, top of unit should be installed 29" (737mm) above finished floor.

The manufacturer reserves the right, without formal notification, to implement changes to the design and dimensions.
 © 2008 Columbia Accessories
 Edition: TT-341-200/001



O Box 181, Columbia, SC 29202
 Phone: 1-866-820-3579 Fax: 1-866-317-2786
 Web Site: <http://www.natpart.com>